

A Guide to Spray Suppression Legislation

Trucks (Motor Vehicles)
Trucks exceeding 7.5 tonnes GVW.

Trailers
Trailers exceeding 3.5 tonnes GVW.

Note: Certain vehicle types such as unbodied and off-road vehicles are exempt

The EU Regulation 109/2011 states

"...with the view to improving road safety, it is important that all commercial vehicles in higher weight categories and with certain minimum design speed should be equipped with an efficient Spray Suppression System"

Spray suppression devices for some non-steer or self steering wheels.

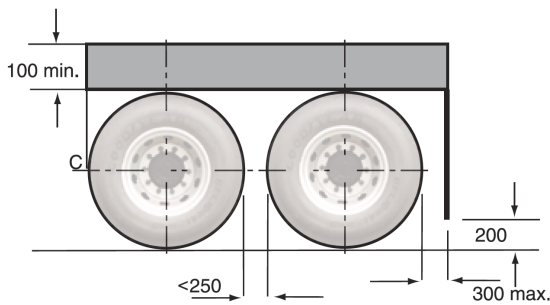

(a) Multiple axles where tyre separation is less than 250mm

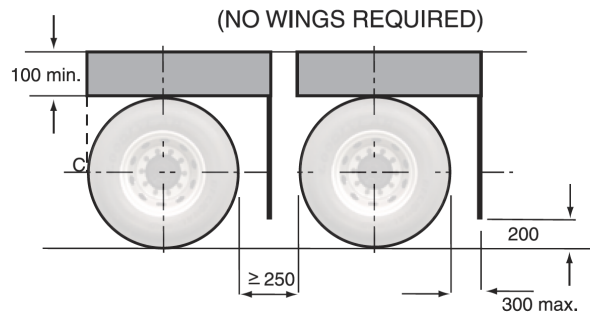

(b) Multiple axles where tyre separation is not less than 250mm

Mudguards and spray suppression devices.

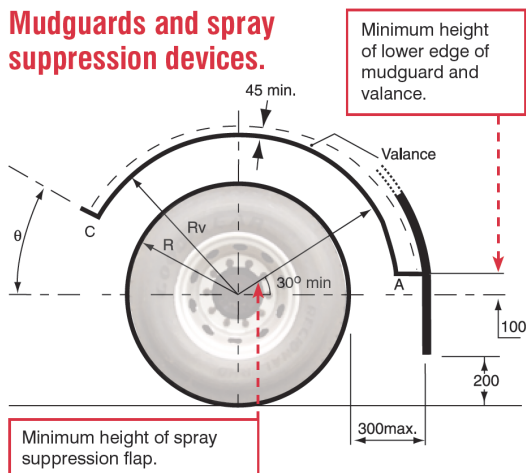

Steered wheels or self-steering wheels:

From the front edge (tip C at 30°)
To the rear edge (tip A at 100mm) $Rv \leq 1.25 R$

Non-steered wheels

From the front edge (tip C at 20°)
To the rear edge (tip A at 100mm) $Rv \leq 1.25 R$

Where

R - is the radius of the tyre
Rv - is the radial distance to the lower edge of the outer valance

Wheel guard, wheel flaps and outer valances for single axles and multiple axles where the distance between tyres is greater than 300mm